



Sydney Boys High School

MOORE PARK

YEAR 10 ADVANCED MATHEMATICS

Half Yearly Examination 2019

General Instructions:

- All questions may be attempted.
- Write using black pen.
- Marks may be deducted for careless or badly arranged work.
- If you wish to rewrite an answer, draw a line through your faulty answer, and rewrite your answer on one of the blank pages of this booklet. Indicate you are doing this. Show the number and part of the answer being rewritten.
- All working and answers are to be written in this test booklet.
- Leave your answers in the simplest exact form, unless otherwise stated.
- NESAs approved calculators may be used.
- Clearly indicate your class by placing an **X** next to your class.

Time Allowed: 90 minutes

Reading Time: 5 minutes

Examiner: J. Chan

Student Name:

Class	Teacher	
10A	Ms B. Kilmore	
10B	Mr S. Gurjar	
10C	Ms J. Millar	
10P	Mr J. James	
10L	Ms H. Chan	
10U	Mr R. Wang	
10S	Ms A. Ward	

Section	Marks
A	/ 14
B	/ 14
C	/ 14
D	/ 14
E	/ 14
F	/ 13
G	/ 12
TOTAL	/ 95

Section A: 14 marks

1) Evaluate $\frac{2.1^2 \times 4.5^2}{2.1^2 + 4.5^2}$, correct to 1 decimal place. **1**

2) Sydney FC is playing Brisbane Roar in a match. If the probability that Sydney will win is $\frac{2}{3}$ and the probability that Brisbane will win is $\frac{1}{4}$, find the chance that the match will be a draw. **1**

3) Simplify the expression $(5a^2b)^2 \times 4a^4b^3$ **2**

4) If m is inversely proportional to n , and $m = 10$ when $n = 25$, what is the value of n when $m = 250$? **2**

5) Solve for the value of x , leave answers in surd form if necessary.

a) $(3x+1)^2 - 25 = 0$

2

b) $\frac{3x-4}{2} = 5 + \frac{x+1}{3}$

2

- 6) a) Sketch $y = \frac{2}{2x+1}$ neatly on a number plane, showing clearly all the asymptotes and possible intercepts. 2

- b) Find the EXACT x -coordinates of the points of intersection for

$$y = \frac{2}{2x+1} \text{ and } 3x - y - 2 = 0$$

2

End of Section A

BLANK PAGE

Section B: 14 marks

1) What is 0.00 523 359 written in scientific notation, correct to 4 significant figures? **2**

2) Find the centre of the circle $x^2 + y^2 - 4x - y + 1 = 0$ **2**

3) Solve $9^x - 26(3^x) - 27 = 0$ **3**

4) Nicole invested \$150 000 at 9% p.a. for 5 years, with the interest compounding every four months. How much interest will she earn? **2**

5) A lawnmower was purchased for \$480 and 4 years later its value depreciated to \$275. Find the annual rate of depreciation. **2**

6) Sketch $y = 4x^2 + 4x - 3$ neatly on a number plane, showing the intercepts and the vertex. **3**

End of Section B

Section C: 14 marks

- 1) The parabola $y = 2x^2 + kx - 7$ has an axis of symmetry with equation $x = 3$.
Find the value of k .

2

- 2) Zachary is going to have 100 cardboard display boxes to contain his company's information pamphlets. Each of the boxes has 4 sides and a base and is open at the top. The dimensions of the boxes are shown in the diagram below. The manufacturer's charge for making the boxes are based on the external surface area of each box. The charge is \$17.50 per square metre.

How much will the manufacturer charge to make 100 display boxes?

3

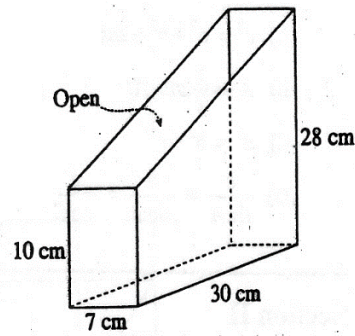

3) Find the values of the pronumerals, x and y , giving reasons for your answers.

3

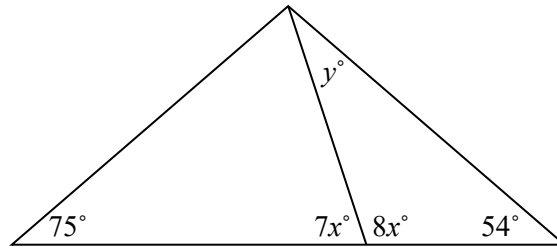

4) The cabin door to an aeroplane is positioned such that 120 passenger seats are to the right side and 40 passenger seats are to the left side of this door. The next flight is full, and a hostess directs passengers to their seats from the door.

a) What is the probability that the hostess directs the first passenger on board to the right side of the door? **1**

b) 20% of the passengers sitting on the left side of the door are travelling first class.

There are no first-class seats on the right side of the door.

Calculate the probability that the first passenger who boards is travelling first class. **1**

5) Alan sat for exams in English, Maths, and Science. The results for the class are shown below:

Test	Class Mean	Class Standard Deviation
English	55	20
Mathematics	70	5
Science	65	10

What mark in Science would Alan have to get to be equivalent to a mark of 80 in Mathematics?

2

6) The graph below is that of $y = -x^2 + 2x + 1$. On this graph, sketch the intersection of the regions determined by $y \leq -x^2 + 2x + 1$ and $y < 2^x$.

Show all essential features.

2

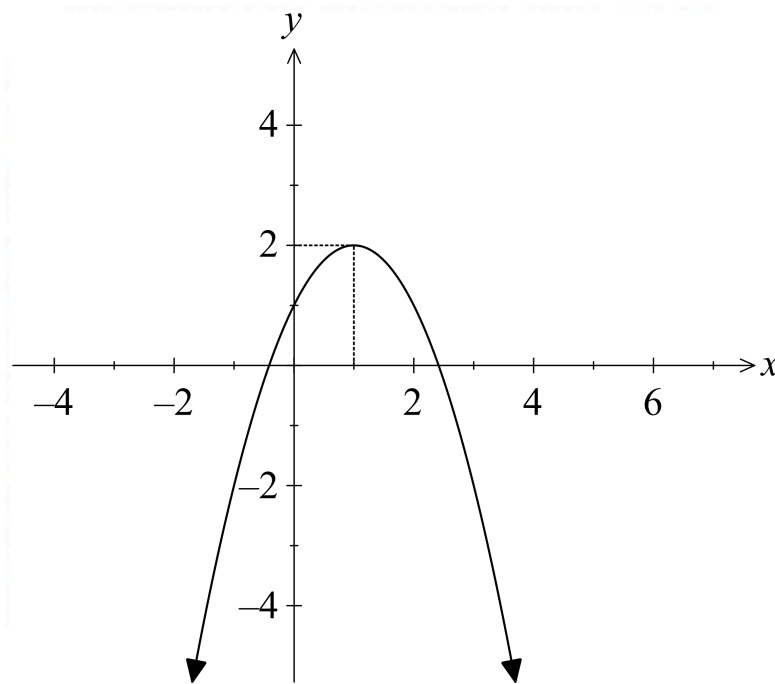

End of Section C

BLANK PAGE

Section D:14 marks

- 1) What is the algebraic expression that represents the shaded area in simplest form?

2

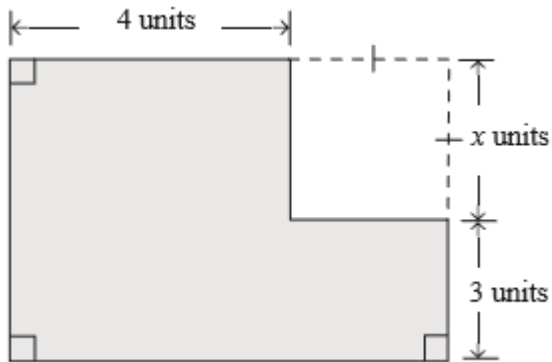

- 2) Matthew borrows \$12000 to buy a motorbike. He is to pay the money back over three years in equal monthly repayments and is charged simple interest at 8% p.a. How much is each instalment?

2

- 3) Expand and simplify $9x^2 + 4xy\left(\frac{y}{4} + \frac{y}{x}\right) - (3x + 2y)^2$.

2

4) The diagram shows two parallel lines s and t .

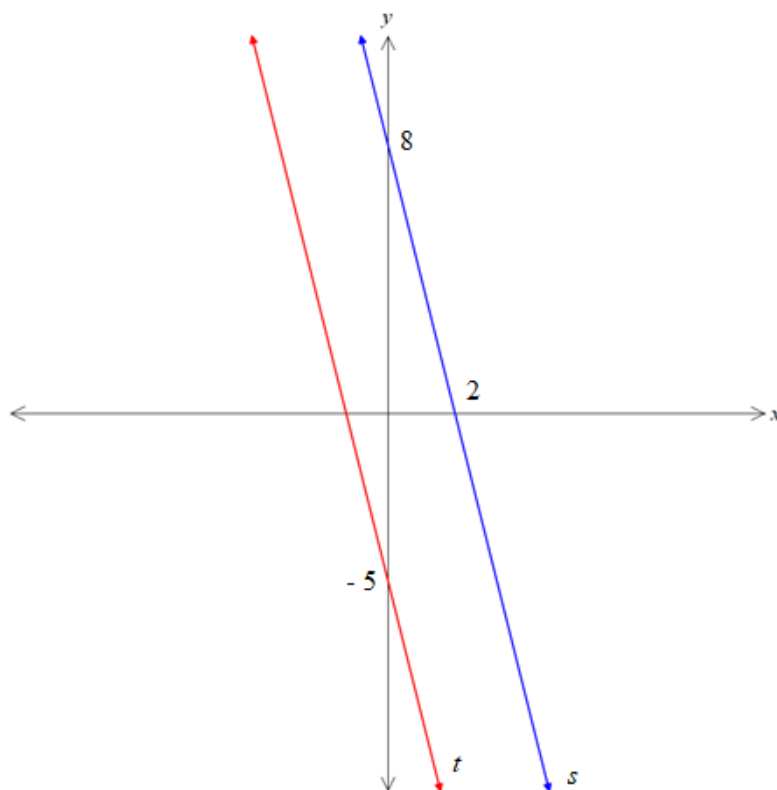

a) Show that the equation of the line t is $4x + y + 5 = 0$ and find the x -intercept of the line t . **2**

b) The point $R(k, 3k)$ lies on the line t . Find the value of k . **1**

- 5) In the diagram, $ABCD$ is a rhombus where $\angle DAC = 54^\circ$ and DC is produced to E .

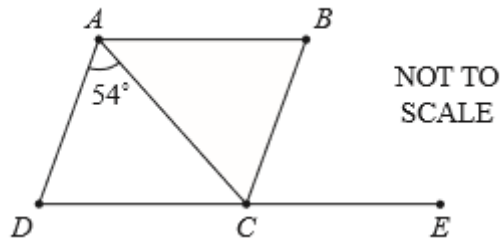

- a) What is the value of $\angle DAB$? 1
- b) What is the value of $\angle BCE$? Give reasons. 2
- 6) Express $\frac{6}{3y-5} - \frac{4}{3y^2-8y+5}$ as a fraction in its simplest form. 2

End of Section D

BLANK PAGE

Section E: 14 marks

Part A: Multiple Choice (1 mark each)

Circle the correct answer clearly.

- 1) The volume of a cone of height 6 m is 301.6 m^3 . What is the volume of a cylinder that has the same dimensions as the cone?
- (A) 100.5 m^3
(B) 134 m^3
(C) 402.1 m^3
(D) 904.8 m^3
- 2) A driveway is found to be 4.251 m long using a tape measure. Calculate the percentage error for this measurement to three decimal places.
- (A) 0.001%
(B) 0.002%
(C) 0.011%
(D) 0.012%
- 3) In the diagram below, $\angle NPQ = 65^\circ$.

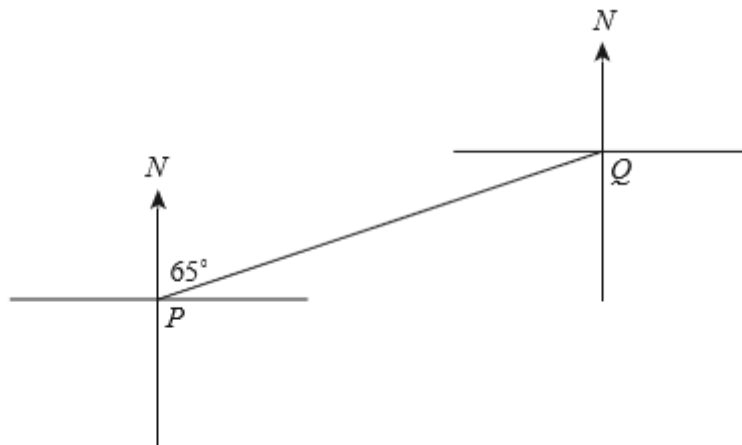

What is the bearing of P from Q?

- (A) 065°T
(B) 117°T
(C) 207°T
(D) 245°T

- 4) A set of data is represented by the cumulative frequency histogram and ogive.

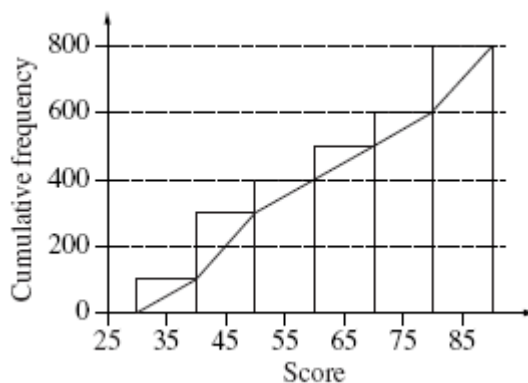

What is the best approximation for the interquartile range for this set of data?

- (A) 25
 - (B) 30
 - (C) 35
 - (D) 40
- 5) The dot plots below are drawn on the same scale. They show the class scores in tests taken before and after a unit of work was completed.

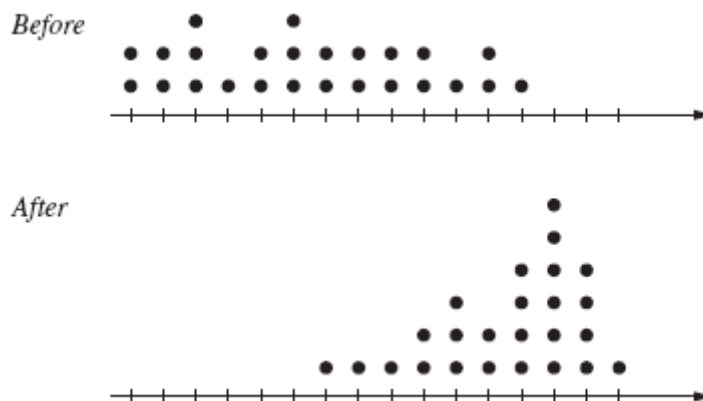

Which statement about the change in scores is correct?

- (A) The mean increased and the standard deviation decreased.
- (B) The mean increased and the standard deviation increased.
- (C) The mean decreased and the standard deviation decreased.
- (D) The mean decreased and the standard deviation increased.

Part B:

- 1) Factorise $9a^2 - 6ab + b^2 - c^2$ completely. 2
- 2) Two points on the number plane $A(2, 2)$ and $B(1, 5)$.
- a) Find the coordinates of M , the midpoint of AB . 1
- b) Find, in general form, the equation of the perpendicular bisector of AB . 2
- 3) The numbers 4, 6, 12, 4, 10, 12, 3, x and y have a mean of 7 and a mode of 4. Find
- a) the value of the two numbers x and y , given that $x < y$. 2
- b) the median 1
- c) the standard deviation of this set of nine numbers to 3 sig. fig. 1

End of Section E

BLANK PAGE

Section F (13 marks)

1)

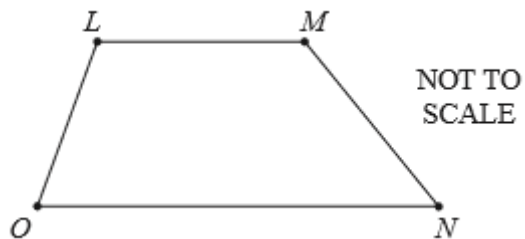

$LMNO$ is a quadrilateral. $\angle LON = \angle MNO$ and $LO = MN$.

a) Prove that the triangle OLN is congruent to triangle NMO .

2

b) Why are $\angle LNO$ and $\angle MON$ equal?

1

c) Prove that $\angle LOM = \angle LNM$.

2

- 2) The figure shows a solid metallic object in the form of a right pyramid with a square base of side 13 cm and a height of 25 cm. The vertex V of the pyramid is directly above the centre of the square base $ABCD$.

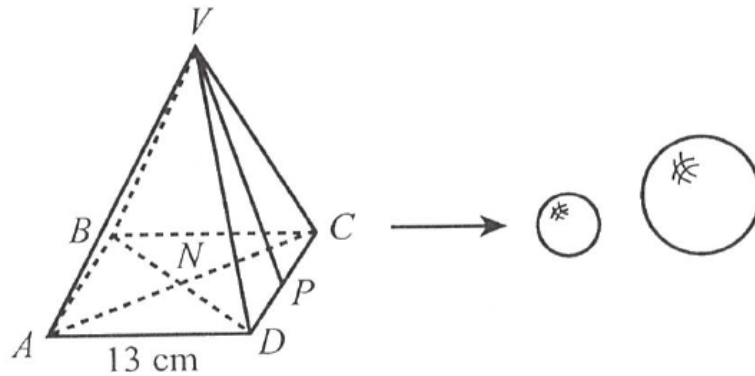

- a) Calculate the surface area of the pyramid to 2 decimal places.

2

- b) The pyramid is melted and recast into two solid spheres, such that the radius of the larger sphere is twice the radius of the smaller sphere.
By letting the radius of the smaller sphere be r cm, calculate the radius of the smaller metallic sphere to 2 decimal places.

3

- 3) The volume of a cylinder of radius r cm, and height h cm varies directly as r^2h .
If the base radius is increased by 50% and the height is decreased by 20%, find the percentage change in the volume.

3

End of Section F

BLANK PAGE

Section G: 12 marks

- 1) Suppose that $k > 0$ and that the line with equation $y = 3kx + 4k^2$ intersects the parabola with equation $y = x^2$ at points P and Q , as shown.

If O is the origin and the area of $\triangle OPQ$ is 80, find the slope of the line PQ .

3

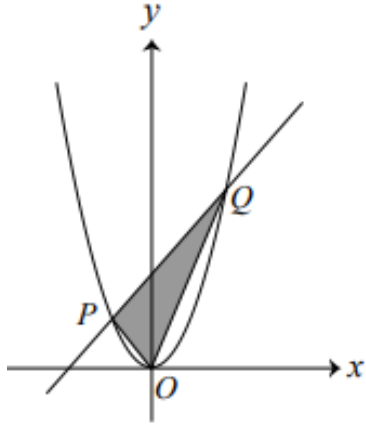

2) a) Find constants A and B such that $4^{3x^2+4x} - 2^{3x^2+4x+3} = A(2^{3x^2+4x})^2 - B(2^{3x^2+4x})$ **3**

b) For which values of x will the expression $4^{3x^2+4x} - 2^{3x^2+4x+3}$ take its minimum value? **2**

- 3) The circle $x^2 + (y - c)^2 = r^2$, where $c > 0$ and $r > 0$, lies inside the parabola $y = x^2$. The circle touches the parabola at exactly two points located symmetrically on opposite side of the y -axis, as shown in the diagram.

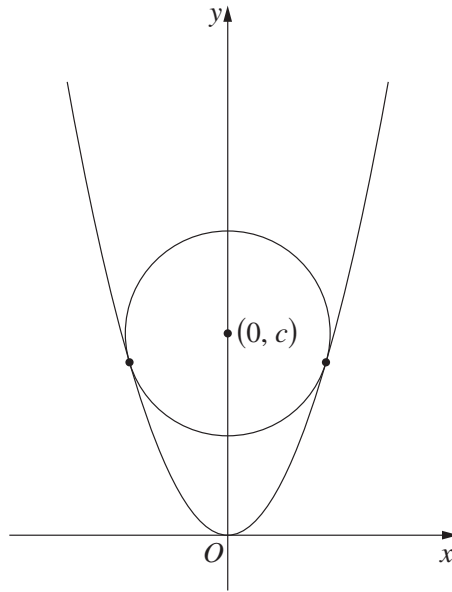

By considering the y -coordinates of where the circle touches the parabola show that

a) $4c = 1 + 4r^2$.

2

b) $c > \frac{1}{2}$

2

END OF EXAMINATION

Extra Working Space



SYDNEY
BOYS
HIGH
SCHOOL

2019

YEAR 10 HALF YEARLY
STAGE 5.3 ADVANCED MATHEMATICS

Sample Solutions

Sections	Teacher
A	JJ
B	RW
C	AW
D	HC
E	JM
F	SG
G	BK

Year 10 HY Section A Solutions (Mr James)

1) $\frac{2.1^2 \times 4.5^2}{2.1^2 + 4.5^2} = 3.6$ to 1 decimal place (no half marks)

2) In soccer there are 3 outcomes: Win, Loss, Draw. If a particular team loses, then the other team wins. If no team wins, then both team draw. Below I have put the probabilities in terms of 1 team: Sydney FC

$$P(W) = \frac{2}{3}, \text{ where } W \text{ is a win. } P(L) = \frac{1}{4}, \text{ where } L \text{ is a loss, i.e. Brisbane Roar wins.}$$

$$P(D) = 1 - (P(W) + P(L)), \text{ where } D \text{ is a draw.}$$

$$P(D) = 1 - \left(\frac{2}{3} + \frac{1}{4} \right)$$

$$P(D) = 1 - \frac{4 \times 2 + 3 \times 1}{3 \times 4}$$

$$P(D) = 1 - \frac{11}{12}$$

$$P(D) = \frac{1}{12} \quad (\text{no half marks})$$

3) $(5a^2b)^2 \times 4a^4b^3 = 25a^4b^2 \times 4a^4b^3$ (1 mark for this)

$$= 25 \times 4a^{4+4}b^{2+3}$$

$$= 100a^8b^5 \quad (\text{full marks for this}) \text{ (-half mark for small arithmetic errors)}$$

4) m is inversely proportional to n means $m = \frac{k}{n}$, where k is a constant belonging to \mathbb{R} .

$$k = mn, m = 10 \text{ when } n = 25 \text{ means that } k = 250$$

$$250 = \frac{250}{n} \text{ when } m = 250, \therefore n = 1 \quad (\text{full marks for this, 1 mark for writing the}$$

right equation, and half a mark for using some sort of ratio)

5)

a) This is the difference of two squares.

$$((3x+1)+5)((3x+1)-5) = 0$$

$$(3x+6)(3x-4) = 0$$

$\therefore x = -2, \frac{4}{3}$ (full marks for this answer and my discretion for different sort of methods that lead invariably to a plethora of mistakes – like forgetting the plus/minus sign and only getting one solution)

$$\text{b) } \frac{3x-4}{2} - \frac{x+1}{3} = 5$$

$$\frac{3(3x-4) - 2(x+1)}{6} = 5$$

$$9x - 12 - 2x - 2 = 30$$

$$7x - 14 = 30$$

$$7x = 44$$

$$x = \frac{44}{7} \text{ (half mark off for small arithmetic errors and a full mark off for not expanding$$

brackets correctly – if that's what you did).

6) A)

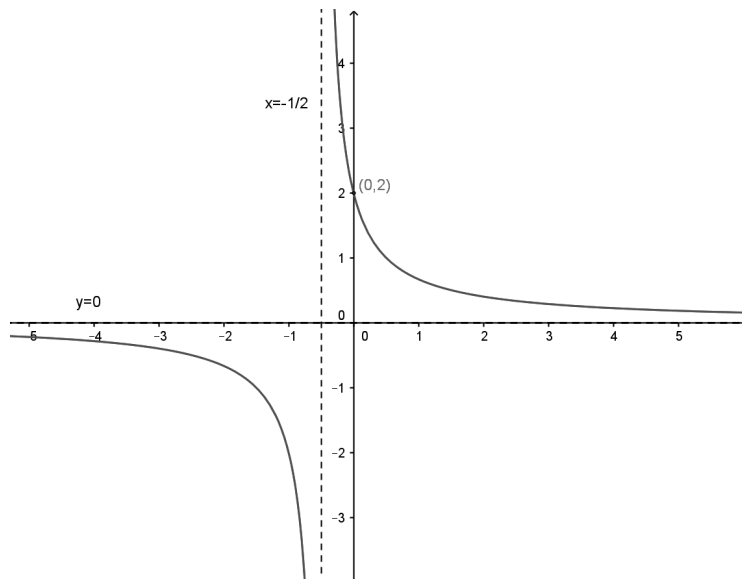

(-half marks for each asymptote missing and not putting in the intercept, or drawing the curve incorrectly)

B) Gradient intercept form of the line in the question is $y = 3x - 2$

$$\text{Then, } 3x - 2 = \frac{2}{2x + 1}$$

$$(2x + 1)(3x - 2) = 2$$

$$6x^2 - x - 2 = 2$$

$$6x^2 - x - 4 = 0 \text{ (1 mark is you got this)}$$

$$x^2 - \frac{x}{6} - \frac{2}{3} = 0$$

$$\left(x - \frac{1}{12}\right)^2 = \frac{2}{3} + \left(\frac{1}{12}\right)^2$$

$$x - \frac{1}{12} = \pm \sqrt{\frac{2 \times 48 + 1}{144}}$$

$$x = \frac{1 + \sqrt{97}}{12}, \frac{1 - \sqrt{97}}{12} \text{ (full marks if you got this) (half marks lost for arithmetic}$$

errors or not using the formulas correctly – completing the square or quadratic formula)

2019 YR10 Half Yearly Solutions – Section B

Question 1: What is 0.00523359 written in scientific notation, correct to 4 significant figures? 2

Solution	Comments
Express in scientific notation: $0.00523359 = 5.23359 \times 10^{-3}$ Round to 4 significant figures: $5.23359 \times 10^{-3} = 5.234 \times 10^{-3} \text{ (4 s.f.)}$	No half marks given. Common errors: <ul style="list-style-type: none"> • Rounding to 5.233

Question 2: Find the centre of the circle $x^2 + y^2 - 4x - y + 1 = 0$. 2

Solution	Comments
Rearrange and complete the square: $x^2 - 4x + y^2 - y = -1$ $(x^2 - 4x + 4) + \left(y^2 - y + \frac{1}{4}\right) = -1 + 4 + \frac{1}{4}$ $(x - 2)^2 + \left(y - \frac{1}{2}\right)^2 = \frac{13}{4}$ Locate the centre: $C = \left(2, \frac{1}{2}\right)$	Most students struggled to complete the square properly. Some students failed to identify a need to complete the square and could not score any marks. Students must have an equivalent answer to $\frac{13}{4}$ on the RHS to avoid being penalised. Common errors: <ul style="list-style-type: none"> • Failing to turn $y^2 - y$ into a perfect square correctly. • Immediately factorising the expression without completing the square.

Question 3: Solve $9^x - 26(3^x) - 27 = 0$. 3

Solution	Comments
Use index laws to rewrite 9^x in terms of 3^x : $(3^2)^x - 26(3^x) - 27 = 0$ $(3^x)^2 - 26(3^x) - 27 = 0$ Let $u = 3^x$ and solve as a quadratic equation: $u^2 - 26u - 27 = 0$ $(u - 27)(u + 1) = 0$ $u = 27 \qquad u = -1$ Substitute $u = 3^x$ into the two solutions and solve: $3^x = 27 \qquad 3^x = -1$ $x = 3 \qquad \text{No solution, as no power can make a positive base turn negative.}$ $\therefore x = 3$	Some students failed to identify the problem as a reducible quadratic equation and could not score any marks. Common errors: <ul style="list-style-type: none"> • Attempting to factorise the LHS without reducing it into a quadratic equation first. • Mistaking $3^x = -1$ to have a solution.

2019 YR10 Half Yearly Solutions – Section B

Question 4: Nicole invested \$150 000 at 9% p.a. for 5 years, with interest compounding every four months. How much interest will she earn? 2

Solution	Comments
<p>Convert interest rate and number of compound periods in terms of quarters, i.e. four-month lots:</p> $R = 9\% \text{ p.a.} \qquad N = 5 \text{ yr}$ $= 0.09 \times \frac{4}{12} \qquad = 5 \times \frac{12}{4}$ $= 0.03 \qquad = 15$ <p>Hence, R is 3% per quarter. Hence, N is 15 quarters.</p> <p>Compound interest formula for calculating interest only is:</p> $I = A - P$ $= P(1 + R)^N - P$ <p>Substitute and solve:</p> $I = 150000(1 + 0.03)^{15} - 150000$ $= \$83695.11$	<p>Some students mistook the problem to be one on simple interest and could not score any marks.</p> <p>Common errors:</p> <ul style="list-style-type: none"> • Not converting to a quarterly rate and quarterly periods. • Incorrectly converting the rate and period. • Not realising that the question is asking for the interest only. • Not rounding to 2 d. p. for problems involving money.

Question 5: A lawnmower was purchased for \$480 and 4 years later its value depreciated to \$275. Find the annual rate of depreciation. 2

Solution	Comments
<p>Rearrange depreciation formula so that depreciation rate is the subject:</p> $A = P(1 - R)^N$ $(1 - R)^N = \frac{A}{P}$ $1 - R = \sqrt[N]{\frac{A}{P}}$ $R = 1 - \sqrt[N]{\frac{A}{P}}$ <p>Substitute and solve:</p> $R = 1 - \sqrt[4]{\frac{275}{480}}$ $= 13.000\% \text{ (3 d. p.)}$	<p>No half marks given.</p> <p>Some students used $A = PRN$, which is incorrect, and could not score any marks.</p> <p>Students who used $A = P(1 + R)^N$ or $A = PR^N$ could only score a maximum of 1 mark.</p> <p>A small number of students bafflingly reached the final expression for R, but did not evaluate it.</p>

2019 YR10 Half Yearly Solutions – Section B

Question 6: Sketch $y = 4x^2 + 4x - 3$ neatly on a number plane, showing the intercepts and the vertex.

3

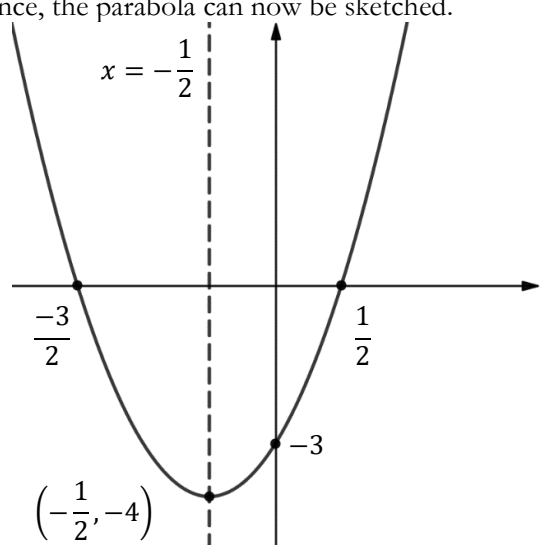
Solution	Comments
<p>Recognise that the equation is quadratic, so its graph is a parabola.</p> <p>Substitute $y = 0$ and solve for x to find the x-intercepts:</p> $4x^2 + 4x - 3 = 0$ $2x \quad \quad \quad 3$ $2x \quad \quad \quad -1$ $\therefore (2x + 3)(2x - 1) = 0$ $x = -\frac{3}{2} \quad \quad \quad x = \frac{1}{2}$ <p>Substitute $x = 0$ and solve for y to find the y-intercept:</p> $y = 4(0)^2 + 4(0) - 3$ $= -3$ <p>Locate the vertex, which lies on the axis of symmetry halfway between the x-intercepts:</p> $V_x = \frac{-\frac{3}{2} + \frac{1}{2}}{2} \quad V_y = 4\left(-\frac{1}{2}\right)^2 + 4\left(-\frac{1}{2}\right) - 3$ $= \frac{-1}{2} \quad \quad \quad = -4$ <p>Evident from the vertex and x-intercepts, the parabola is concave up.</p> <p>Hence, the parabola can now be sketched.</p> 	<p>Students who showed no or insufficient working out could not score full marks, even if they sketched the correct parabola.</p> <p>A small number of students did not recognise that the curve was a parabola despite correctly locating all intercepts and the vertex.</p> <p>Common errors:</p> <ul style="list-style-type: none"> • Forgetting to locate the y-intercept. • Finding an incorrect y-coordinate for the vertex.

General feedback:

- There was no observable trend in overall student performance: Some did well, some did not.
- Completing the square and reducible quadratic equations were areas of weakness.
- Most students demonstrated very poor curve-sketching skills.

Section C: 14 marks

- 1) The parabola $y = 2x^2 + kx - 7$ has an axis of symmetry with equation $x = 3$.

2

Find the value of k .

$$x = \frac{-b}{2a} = 3$$

$$= \frac{-k}{4} = 3$$

$$\underline{k = -12}$$

$$-\frac{b}{2a} \text{ (1)}$$

$$-12 \text{ (1)}$$

wrong sign $(-\frac{1}{2})$

POORLY DONE

Many just subs. 3

- 2) Zachary is going to have 100 cardboard display boxes to contain his company's information pamphlets. Each of the boxes has 4 sides and a base and is open at the top. The dimensions of the boxes are shown in the diagram below. The manufacturer's charge for making the boxes are based on the external surface area of each box. The charge is \$17.50 per square metre.

How much will the manufacturer charge to make 100 display boxes?

3

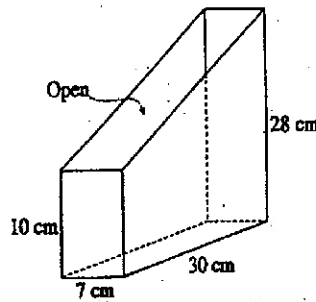

$$SA = \text{base} + \text{front} + \text{back} + \text{side} \times 2$$

$$= 30 \times 7 + 10 \times 7 + 28 \times 7 + \frac{30}{2} (28 + 10) \times 2$$

$$= 210 + 70 + 196 + 1140$$

$$= 1616 \text{ cm}^2$$

(1) area

$$100 \times SA = 161600 \text{ cm}^2$$

$$= 1616 \text{ m}^2$$

(1) conversion

$$\text{Cost} = 1616 \times 17.50$$

$$= \$282.80$$

(1) Answer

ABOUT 50% CORRECT

COMMON ERRORS

1. Area was poorly found

2. Conversion to m^2 incorrect

3) Find the values of the pronumerals, x and y , giving reasons for your answers.

3

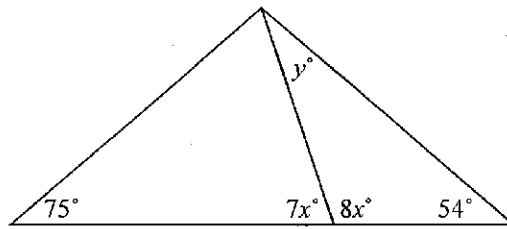

15x = 180 (Angles on a straight line) ①

x = 12

y + 8x + 54 = 180 (∠ sum Δ) ①

y = 180 - 54 - 8(12)

x = 12, y = 30 ①

① 1/2 NO REASONS

① 1/2 only 1 reason

VERY WELL DONE

4) The cabin door to an aeroplane is positioned such that 120 passenger seats are to the right side and 40 passenger seats are to the left side of this door. The next flight is full, and a hostess directs passengers to their seats from the door.

a) What is the probability that the hostess directs the first passenger on board to the right side of the door?



$P(\text{right}) = \frac{120}{160} = \frac{3}{4}$

① 1/2 not simplified: 1

VERY WELL DONE

b) 20% of the passengers sitting on the left side of the door are travelling first class.

There are no first-class seats on the right side of the door.

Calculate the probability that the first passenger who boards is travelling first class.

1

20% of 40 = 8, passengers. ②

$P(1^{\text{st}} \text{ class}) = \frac{8}{160} = \frac{1}{20}$ ③

REASONABLY WELL DONE

5) Alan sat for exams in English, Maths, and Science. The results for the class are shown below:

Test	Class Mean	Class Standard Deviation
English	55	20
Mathematics	70	5
Science	65	10

What mark in Science would Alan have to get to be equivalent to a mark of 80 in Mathematics?

2

$$\text{Maths} = 80 = 70 + 2(5)$$

$$\text{Science} = x = 65 + 2(10)$$

$$\text{Science} = 85$$

Recognising 2SD in both cases ①

POORLY DONE

Many did not attempt.

6) The graph below is that of $y = -x^2 + 2x + 1$. On this graph, sketch the intersection of the regions determined by $y \leq -x^2 + 2x + 1$ and $y < 2^x$.

Show all essential features.

2

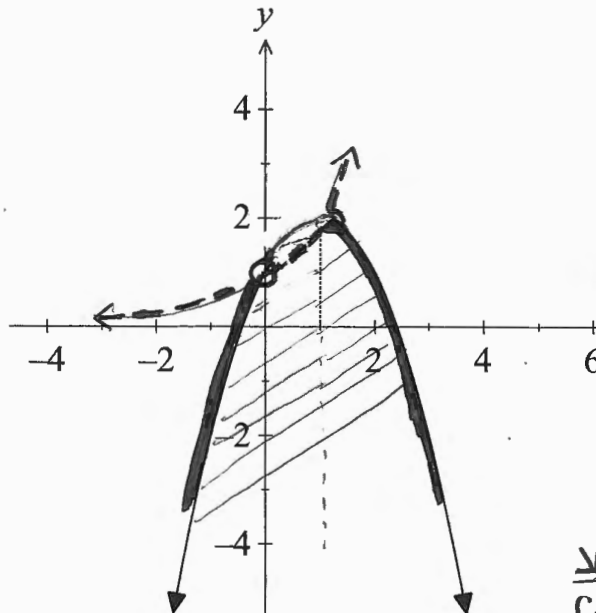

STUDENTS WERE NOT PENALISED FOR NO HOLLOW CIRCLES FOR EXCLUDED VALUES

① $y = 2^x$ correct.

② $-\frac{1}{2}$ Incorrect Area
③ $-\frac{1}{2}$ no dotted line

VERY POORLY DONE

Common errors.

1. no dotted line for $y = 2^x$
2. no or incorrect area
3. wrong shape for $y = 2^x$

Section D:14 marks

- 1) What is the algebraic expression that represents the shaded area in simplest form?

2

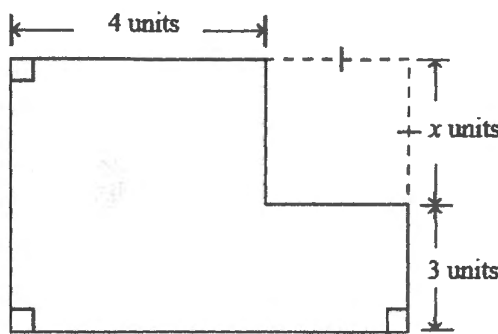

$$(4+x)(3+x) - x^2$$

$$= 12 + 4x + 3x + x^2 - x^2$$

$$= \underline{\underline{7x + 12 \text{ unit}^2}}$$

OR

$$4(x+3) + 3x$$

$$= 4x + 12 + 3x$$

$$= \underline{\underline{7x + 12 \text{ unit}^2}}$$

OR

$$4x + 3(4+x)$$

$$= 4x + 12 + 3x$$

$$= \underline{\underline{7x + 12 \text{ unit}^2}}$$

- 2) Matthew borrows \$12000 to buy a motorbike. He is to pay the money back over three years in equal monthly repayments and is charged simple interest at 8% p.a. How much is each instalment?

2

$$\frac{\$(12000 \cdot (8\%) \cdot 3 + 12000)}{3 \times 12}$$

$$= \underline{\underline{\$413.33 \text{ (correct to 2 dp)}}}$$

- 3) Expand and simplify $9x^2 + 4xy\left(\frac{y}{4} + \frac{y}{x}\right) - (3x+2y)^2$.

2

$$= 9x^2 + xy^2 + 4y^2 - (9x^2 + 12xy + 4y^2)$$

$$= 9x^2 + xy^2 + 4y^2 - 9x^2 - 12xy - 4y^2$$

$$= \underline{\underline{xy^2 - 12xy}}$$

OR $= xy(y-12)$

4) The diagram shows two parallel lines s and t .

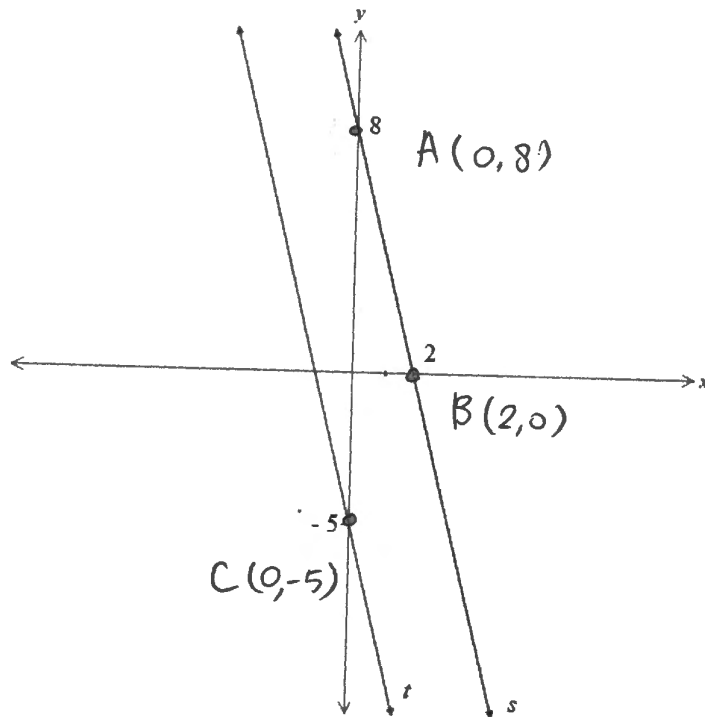

a) Show that the equation of the line t is $4x + y + 5 = 0$ and find the x-intercept of the line t . 2

sub $x=0, y=-5$ into $4x+y+5=0$ $m_s = \frac{8-0}{0-2} = -\frac{8}{2} = -4$

$4(0) + (-5) + 5 = 0$ OR $-4 = \frac{y-5}{x-0}$

\therefore equation of line t is $4x + y + 5 = 0$ $-4x = y + 5$
 $0 = 4x + y + 5$

sub $y=0$ into $4x + y + 5 = 0$

$4x + 5 = 0$
 $x = -\frac{5}{4}$

b) The point $R(k, 3k)$ lies on the line t . Find the value of k . 1

sub $x=k$

$y=3k$

into $4x + y + 5 = 0$

$4k + 3k + 5 = 0$

$7k + 5 = 0$

$k = -\frac{5}{7}$

- 5) In the diagram, $ABCD$ is a rhombus where $\angle DAC = 54^\circ$ and DC is produced to E .

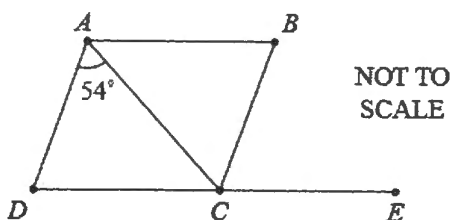

- a) What is the value of $\angle DAB$?

$$108^\circ \quad \begin{aligned} \angle DAC &= \angle BAC = 54^\circ \text{ (diagonals bisect } \angle\text{s)} \\ \angle DAB &= \angle DAC + \angle BAC = 54^\circ + 54^\circ = 108^\circ \end{aligned}$$

1

- b) What is the value of $\angle BCE$? Give reasons.

$$\begin{aligned} \angle DCB &= \angle DAB = 108^\circ \text{ (opp } \angle\text{s. eg in rhombus)} \\ \angle BCE &= 180^\circ - \angle DCB \text{ (supplementary } \angle\text{s)} \\ &= 180^\circ - 108^\circ \\ &= \underline{\underline{72^\circ}} \end{aligned}$$

2

- 6) Express $\frac{6}{3y-5} - \frac{4}{3y^2-8y+5}$ as a fraction in its simplest form.

2

$$\begin{aligned} &\frac{6}{3y-5} - \frac{4}{(3y-5)(y-1)} \\ &= \frac{6(y-1) - 4}{(3y-5)(y-1)} \\ &= \frac{6y-6-4}{(3y-5)(y-1)} \\ &= \frac{6y-10}{(3y-5)(y-1)} \\ &= \frac{2(3y-5)}{(3y-5)(y-1)} = \frac{2}{y-1} \end{aligned}$$

End of Section D

Section E

Part A

1. $\frac{1}{3} V_{\text{cylinder}} = V_{\text{cone}}$

$$\begin{aligned}\therefore V_{\text{cyl.}} &= 3 \times V_{\text{cone}} \\ &= 3 \times 301.6 \\ &= 904.8 \text{ m}^3\end{aligned}$$

A

2. Percentage Error = $\frac{\text{Absolute Error}}{\text{measurement}} \times 100\%$

$$= \frac{0.0005}{4.251} \times 100\%$$

$$= 0.0117619\dots$$

$$\approx 0.012$$

(3.d.p)

D

3.

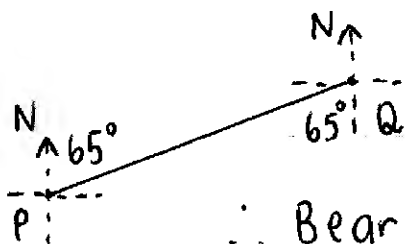

\therefore Bearing of P from Q

$$= 180^\circ + 65^\circ$$

$$= 245^\circ$$

D

4.

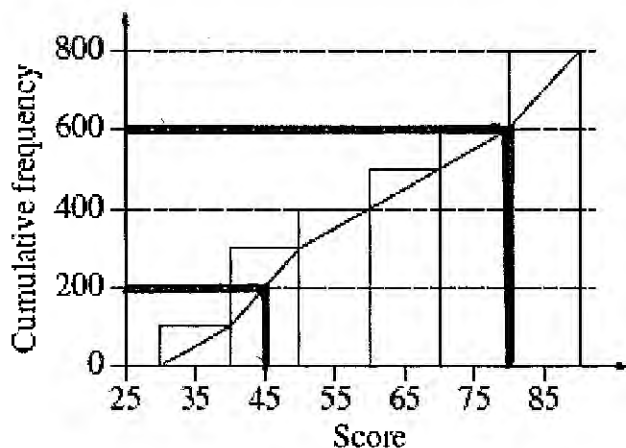

$$Q_1 = 45$$

$$Q_3 = 80$$

$$\therefore \text{IQR} = Q_3 - Q_1$$

$$= 80 - 45$$

$$= 35$$

D

5.

Before

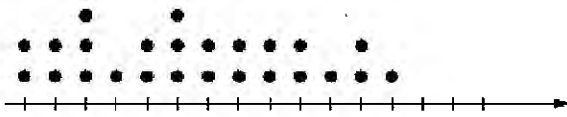

$\text{range}(\text{after}) < \text{range}(\text{before})$

After

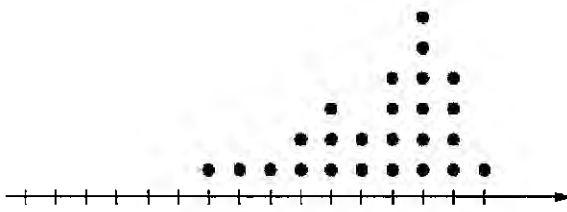

$\text{scores}(\text{after}) > \text{scores}(\text{before})$

\therefore mean increases and standard deviation decreases.

C

Part B

$$\begin{aligned} 1. \quad & 9a^2 - 6ab + b^2 - c^2 \\ &= (9a^2 - 6ab + b^2) - c^2 \\ &= (3a - b)^2 - c^2 \\ &= [(3a - b) - c][(3a - b) + c] \\ &= (3a - b - c)(3a - b + c) \end{aligned} \quad [2]$$

$$2. \quad A = (2, 2), B = (1, 5)$$

$$\begin{aligned} \text{a) midpoint}_{AB} &= \left(\frac{2+1}{2}, \frac{2+5}{2} \right) \\ &= \left(\frac{3}{2}, \frac{7}{2} \right) \end{aligned} \quad [1]$$

b) perpendicular bisector:

$$\begin{aligned} m_1 &= \frac{5-2}{1-2} \\ &= \frac{3}{-1} \\ &= -3 \quad \Rightarrow m_2 = \frac{-1}{m_1} \\ &= \frac{-1}{-3} \\ &= \frac{1}{3} \end{aligned}$$

$$\therefore y - y_1 = m(x - x_1)$$
$$y - \frac{7}{2} = \frac{1}{3} \left(x - \frac{3}{2} \right)$$

$$y - \frac{7}{2} = \frac{x}{3} - \frac{1}{2}$$

$$6y - 21 = 2x - 3$$

$$\therefore 2x - 6y + 18 = 0$$

$$x - 3y + 9 = 0$$

[2]

3. 4, 6, 12, 4, 10, 12, 3, x and y.
mean = 7 and mode = 4

$$a) 7 = \frac{4 + 6 + 12 + 4 + 10 + 12 + 3 + x + y}{9}$$

$$63 = 51 + x + y$$

$$\therefore x + y = 12 \quad \text{however mode} = 4$$

$$\therefore x = 4$$

$$\therefore 4 + y = 12$$
$$y = 8 \quad [2]$$

b) 3, 4, 4, 4, 6, 8, 10, 12, 12

$$\therefore \text{median} = 6 \quad [1]$$

c) standard deviation $\sigma_x = 3.40$ (2.d.p)
[1]

Section F

1) a) In $\triangle OLN$ and $\triangle NMO$

$$LO = MN \text{ (given)}$$

$$\angle LON = \angle MNO \text{ (given)}$$

ON is common

$$\therefore \triangle OLN \cong \triangle NMO \text{ (SAS)}$$

Comments

Done well by some, but many poor answers and some non-attempts. Common mistakes include thinking that LN bisects $\angle MNO$, and that $LMNO$ is a trapezium.

To the 1st point, imagine the quadrilateral as \rightarrow
It should be clear that $\angle LOM \neq \angle MON$,

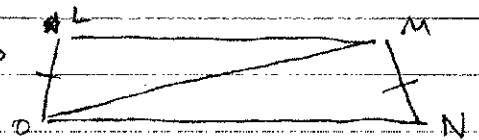

which is what the statement OM bisects $\angle LON$ would mean.

To the 2nd point, although $LMNO$ is a trapezium, it has not been proven, or told to you. Therefore you cannot assume $LM \parallel ON$.

Marking - 2 marks for complete answer. Various $\frac{1}{2}$, 1 & $1\frac{1}{2}$ marks for correct relevant working.

b) The statement "matching angles in congruent triangles are equal", or similar, to get the mark. Just "congruent triangles" is insufficient.

c) Method 1

It is given that $\angle LON = \angle MNO$ and $\angle LNO = \angle MON$

$$\text{LHS} = \angle LOM$$

$$= \angle LON - \angle MON$$

$$= \angle MNO - \angle LNO$$

$$= \angle LNM = \text{RHS}$$

Some people introduce unknowns (eg. x and y), which is fine, but clear explanations are given.

Some students only wrote "because $\angle LON = \angle MNO$ and $\angle LNO = \angle MON$ ", which is insufficient for full marks.

Method 2

In $\triangle LOM$ and $\triangle LNM$,

$$LO = MN \text{ (given)}$$

LM is common

$OM = LN$ (matching sides in congruent triangles are equal)

$$\therefore \triangle LOM \cong \triangle LNM \text{ (SSS)}$$

$$\therefore \angle LOM = \angle LNM \text{ (matching angles in congruent triangles are equal)}$$

This method was done successfully more often, but many students were penalised for fudging their congruence proof.

$$2) a) PN = \frac{1}{2} \times AD$$

$$= \frac{13}{2} = 6.5 \quad \leftarrow \text{SO MANY students think that } \frac{13}{2} = 7.5$$

I don't even know...

$$VP = \sqrt{6.5^2 + 25^2}$$

$$= \frac{\sqrt{2669}}{2}$$

$$\approx 25.8312 \quad (\text{rounding early leads to small errors later})$$

\leftarrow SOME ERRORS with minus sign,

many were using 13 instead of 6.5

$$SA = 4 \times \text{triangles} + 1 \times \text{square base}$$

$$= 4 \times \frac{1}{2} \times 13 \times \frac{\sqrt{2669}}{2} + 13^2$$

$$\approx 840.61 \text{ cm}^2$$

② Correct answer. Students were not penalised for rounding error.

① Any significant single error, but clear correct working everywhere else.

b) MANY students seemed to think the pyramid is hollow, and that the surface is remolded into 2 spheres. This is a question about VOLUME.

$$\text{Volume of Pyramid} = \frac{1}{3} \times 13^2 \times 25$$

$$= \frac{4225}{3}$$

Many students misunderstood the concepts around volume. If $r_1 = 2r_2$,

$$V_1 = 8V_2, \text{ not } V_1 = 2V_2!$$

$$\text{Combined volume} = \frac{4}{3} \pi r^3 + \frac{4}{3} \pi (2r)^3$$

$$= \frac{4}{3} \pi r^3 + \frac{4}{3} \times \pi \times 8r^3$$

$$= \frac{36}{3} \pi r^3 = 12 \pi r^3$$

Many issues with these algebraic steps

Combined Volume = Volume of Pyramid

$$12\pi r^3 = \frac{4225}{3}$$

$$r^3 = \frac{4225}{36\pi}$$

$$r = \sqrt[3]{\frac{4225}{36\pi}} \approx 3.34 \text{ cm.}$$

③ Completely correct

② If the combined volume is incorrect, but equally difficult to solve for 'r'.

①½ Calculations done with SA exclusively.

① Only pyramid volume calculated.

3) $V \propto r^2 h$

$$= k \cdot r^2 h$$

$$\text{Increased volume} = k \times (1.5)^2 r^2 \times (0.8) h$$

$$= 1.8 k r^2 h$$

∴ New volume is 180% of original

∴ There is an 80% increase.

Comments - Many sorts of mistakes:

Only calculating $1.5 \times 0.8 = 1.2$

Calculating $1.5^2 \times 1.2$

Not explicitly calculating the increase (ie. 180% as answer)

Calculating $\frac{1}{1.8} \approx 55.5\%$

② No mistake

① One mistake

Compounded mistakes meant no marks.

Section G: 12 marks

- 1) Suppose that $k > 0$ and that the line with equation $y = 3kx + 4k^2$ intersects the parabola with equation $y = x^2$ at points P and Q , as shown.

If O is the origin and the area of $\triangle OPQ$ is 80, find the slope of the line PQ .

3

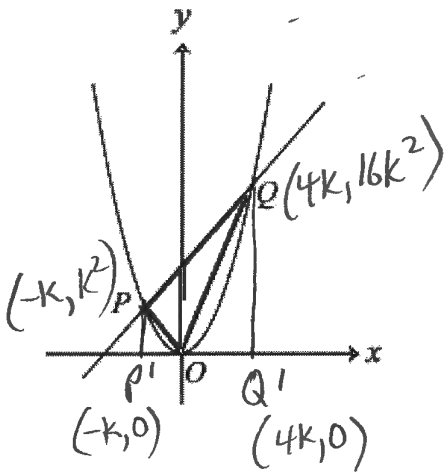

$$y = 3kx + 4k^2 \quad (1) \quad (\text{where } m = 3k \text{ slope})$$

$$y = x^2 \quad (2)$$

$$\text{Sub (2) in (1)} \Rightarrow x^2 = 3kx + 4k^2$$

$$\Rightarrow x^2 - 3kx - 4k^2 = 0$$

$$x = \frac{3k \pm \sqrt{9k^2 + 16k^2}}{2}$$

$$x = \frac{3k \pm 5k}{2}$$

$$\text{When } x = -k, y = k^2 \Rightarrow P = (-k, k^2)$$

$$\text{When } x = 4k, y = 16k^2 \Rightarrow Q = (4k, 16k^2)$$

$$\text{Then Area } \triangle OPQ = \text{Area Trapezium } PQQ'P' - \text{Area } \triangle PP'O - \text{Area } \triangle QQ'O$$

$$\text{Also } d_{QQ'} = 16k^2, d_{PP'} = k^2 \text{ and } d_{P'Q'} = 5k$$

$$\text{Then Area} = \frac{1}{2}(16k^2 + k^2)5k - \frac{1}{2}(k)k^2 - \frac{1}{2}(4k)16k^2$$

$$= \frac{1}{2} \times 85k^3 - \frac{1}{2}k^3 - \frac{1}{2} \times 64k^3$$

$$\Rightarrow 80 = 10k^3$$

$$k^3 = 8$$

$$\Rightarrow \underline{k = 2}$$

$$\therefore \text{slope of line } PQ = \underline{3k = 6}$$

3

a) Find constants A and B such that $4^{3x^2+4x} - 2^{3x^2+4x+3} = A(2^{3x^2+4x})^2 - B(2^{3x^2+4x})^3$

$$2^{6x^2+8x} - 2^{3x^2+4x+3} = A(2^{6x^2+8x}) - B(2^{3x^2+4x})^3$$

Equating coefficients $\Rightarrow A=1$ ✓

$$\text{Also } 2^{3x^2+4x+3} = 2^{3x^2+4x} \cdot 2^3 = B(2^{3x^2+4x}) \quad \checkmark$$

$$\Rightarrow B = 2^3 = 8$$

3

b) For which values of x will the expression $4^{3x^2+4x} - 2^{3x^2+4x+3}$ take its minimum value?

$$\text{From (a) } 4^{3x^2+4x} - 2^{3x^2+4x+3} = (2^{3x^2+4x})^2 - 8(2^{3x^2+4x})$$

$$\text{Let } 2^{3x^2+4x} = n$$

$$\Rightarrow y = n^2 - 8n$$

$$\text{Min value at } n = \frac{-b}{2a} = \frac{8}{2} = 4$$

$$\text{When } n = 4, 2^{3x^2+4x} = 4$$

$$2^{3x^2+4x} = 2^2$$

$$\Rightarrow 3x^2 + 4x = 2$$

$$3x^2 + 4x - 2 = 0$$

$$x = \frac{-4 \pm \sqrt{16+24}}{6}$$

$$\Rightarrow x = \frac{2 \pm \sqrt{10}}{3}$$

which are values of x that make the quadratic a minimum.

2

- 3) The circle $x^2 + (y-c)^2 = r^2$, where $c > 0$ and $r > 0$, lies inside the parabola $y = x^2$. The circle touches the parabola at exactly two points located symmetrically on opposite side of the y -axis, as shown in the diagram.

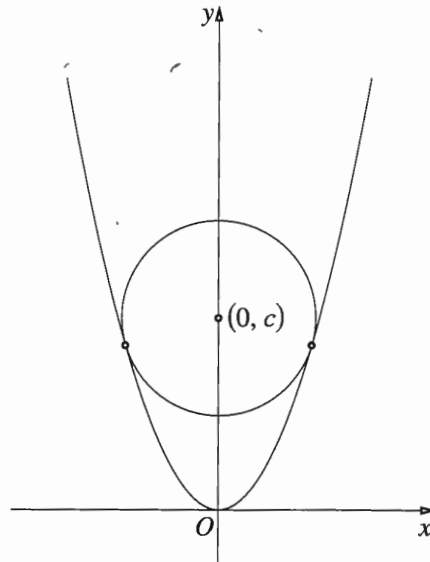

By considering the y -coordinates of where the circle touches the parabola show that

a) $4c = 1 + 4r^2$.

$$x^2 + (y-c)^2 = r^2 \quad (1)$$

$$y = x^2 \quad (2)$$

Sub (2) in (1) $\Rightarrow y + (y-c)^2 = r^2$

$$\Rightarrow y^2 + (1-2c)y + (c^2 - r^2) = 0$$

Now $\Delta = 0$ since only 1 soln for y .

$$\Rightarrow (1-2c)^2 - 4(c^2 - r^2) = 0 \quad 2$$

$$\Rightarrow 4c^2 - 4c + 1 - 4c^2 + 4r^2 = 0$$

$$\Rightarrow 4r^2 + 1 = 4c \quad \# \checkmark$$

(2)

b) $c > \frac{1}{2}$

$$y^2 + (1-2c)y + (c^2 - r^2) = 0 \quad \checkmark$$

$$\Delta = 0 \Rightarrow y = \frac{2c-1 \pm \sqrt{0}}{2} > 0 \quad (\text{since } y > 0)$$

$$\Rightarrow 2c-1 > 0$$

$$\underline{c > \frac{1}{2}} \quad \checkmark$$

(2)

If students did the following they got 1 mark:

$$4c = 4r^2 + 1$$

$$c = r^2 + \frac{1}{4}$$

$$r^2 = c - \frac{1}{4}$$

$$\Rightarrow c - \frac{1}{4} > 0 \quad (\text{since } r^2 > 0)$$

$$c > \frac{1}{4}$$

END OF EXAMINATION